

MODEL LUT-SHUNT-FM INSTALLATION INSTRUCTIONS

! IMPORTANT SAFEGUARDS !

WHEN USING ELECTRICAL EQUIPMENT, BASIC SAFETY PRECAUTIONS SHOULD ALWAYS BE FOLLOWED, INCLUDING THE FOLLOWING:

READ AND FOLLOW ALL SAFETY INSTRUCTIONS

1. This product can be used with LED, ballast, tungsten, and general use loads.
2. Make sure all connections are in accordance with the National Electrical Code and local regulations.
3. To reduce the risk of electric shock, disconnect both normal and emergency power supplies before servicing.
4. This product is intended to be used to control indoor and outdoor located loads.
5. An unswitched AC power source is required (120-240VAC/277VAC).
6. Do not install near gas or electric heaters.
7. Do not attempt to service a sealed Emergency Power Control. When malfunctioning, return to the manufacturer: LVS, Inc. 2555 Nicholson Street, San Leandro, CA 94577.
8. The use of accessory equipment is not recommended by the manufacturer and may cause unsafe condition.
9. Do not use this product for other than its intended use.
10. Servicing should be performed by qualified service personnel.
11. Equipment should be mounted in locations and at heights where it will not readily be subjected to tampering by unauthorized personnel.

SAVE THESE INSTRUCTIONS

5-Year Limited Warranty

LVS, Inc. warrants to the original purchaser/user for the published warranty period from the date of shipment that should LVS instruments or equipment prove defective by reason of improper workmanship or material, LVS will repair or replace the same equipment without charge. This warranty does not cover defects or malfunctions arising from improper installation, operation or repair, or neglect, accident, or abuse. LVS will honor its warranty provided the equipment has not been physically damaged or improperly installed or connected. To obtain warranty/repair, the defective product should be shipped freight prepaid within the warranty period to the address below. To the extent permitted by applicable law, all warranties extending beyond repair or replacement as described above are disclaimed, including the implied warranties of merchantability and fitness for a particular purpose. Where applicable law prohibits disclaimers or the implied warranties of merchantability and fitness; those warranties are limited to 12 months from date of shipment. LVS provides a 90 day money back guarantee if equipment does not perform in accordance with LVS published specifications. The liability of LVS and its agents under all warranties is limited to repair and replacement as described herein and under no circumstances shall there be liability for any other kind of loss, damage, or labor, either consequential or for injury to person or property or otherwise.

Electrical Specifications

120-240/277V Sensing Input
Form C (N.O+N.C.) Contact
3 Amp Electronic/LED Load Rating (120-277V)
5 Amp Ballast Load Rating (120-277V)
5 Amp General Use Rating (120-277V)
360W Incandescent Load Rating (120V)
600W Incandescent Load Rating (277V)
UL924 Listed (usUL/cUL)



Mechanical Specifications

Fixture or Panel Mount
Damp Location Rated
Shipping Weight: 6 oz Color : Black
Temperature: -40°C-65°C (14°F - 149°F)
Body Size: 5"x1"x1.25" (125mmx25.4mmx30mm)

Application

In the past, all emergency lights were left on 24 hours a day to meet safety codes. Now you can specify & install a **UL924 Listed Emergency Shunt Relay LUT-SHUNT-FM**, which converts a normal light fixture into an approved emergency light. During normal operation, the LUT-SHUNT-FM switches designated emergency light on and off. During a utility power interruption, the LUT-SHUNT-FM turns designated emergency light on, regardless of switch position.

Intended for use with switching and line voltage dimming controls.

What is the difference between a SHUNT and an ALCR?

An emergency shunt relay requires a dedicated switch/dimmer to control the emergency lights. In other words, the switch/dimmer must be wired on the emergency power circuit.

An automatic load control relay allows the same switch/dimmer to control both normal and emergency lights. In other words, the switch/dimmer can be wired on the normal power circuit.

Slim Fixture Mount Installation

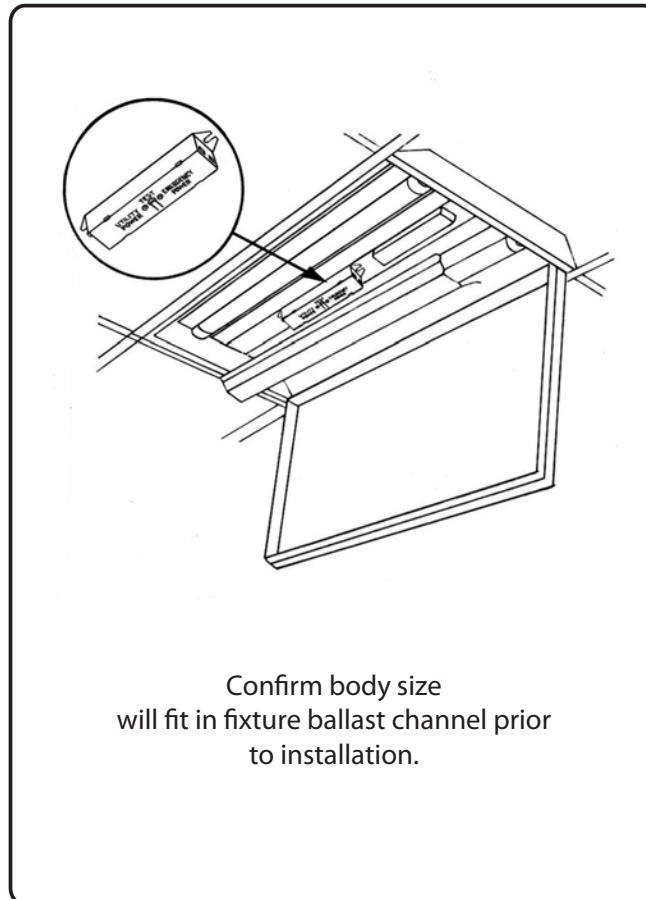

Installation

In order to install the LUT in accordance with national/local code requirements, a qualified electrician should review & understand the installation instructions. Check voltage & current requirements. Verify & lock out circuit breakers on both regular (utility) power & 24 hour emergency generator or inverter circuit. Install a self-adhesive 2" x 3" caution label in each fixture or load controlled by an LUT cautioning that the load is supplied from 2 different power sources, normal & emergency. Review wiring diagram & connect wires, one at a time, in accordance with the numeric identification. In order to provide a safe light level, when regular power is interrupted, it is recommended that a minimum of approximately 5000 lumen are controlled by a 24 hour emergency circuit & are spaced no farther than 24' in any direction from each other in a normal 9' white ceiling environment.

Initial Testing and Troubleshooting

In a new installation, where hundreds of devices may be used, each having as many as 14 wires to be correctly connected, it is important that a fast, convenient method is used to check connections. In order to test that the wires are connected correctly, without any inconvenience to occupants, do not turn off regular (utility) power off until you have checked each device as follows:

- 1) Check that regular branch circuit breaker is connected & utility power is available. Green LED should be lit. If green LED is not lit, check connections & continuity to branch circuit breaker.
- 2) Check that emergency branch circuit breaker is connected & emergency power is available.
- 3) Normal Operation Test: Turn switch or other control device to the "ON" position. Emergency light should turn on. Turn room switch or control to the "OFF" position. Emergency light should turn off.
- 4) Emergency Operation Test: Press and hold test button, emergency light should illuminate at full brightness until test button is released.

Maintenance

No maintenance is required to keep the LUT functional. However, regular testing should be performed when the lamps or ballasts have been replaced or when remodeling has taken place.

Single Line Drawings

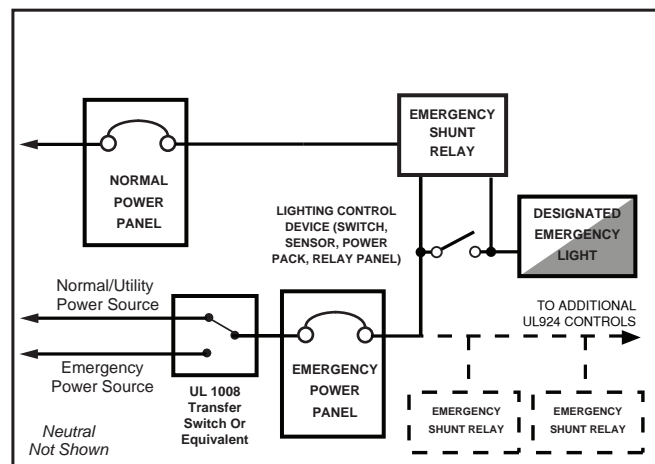
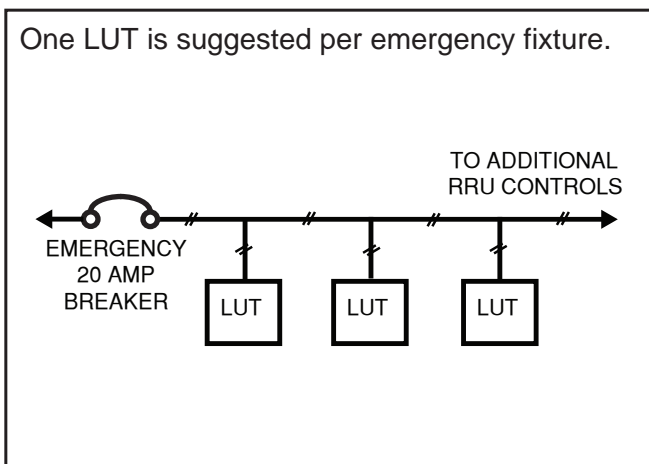

Wiring Diagram #1: A dedicated switch or line voltage dimmer controls emergency lighting in a space. Upon loss of normal power, the emergency lighting comes on at full brightness regardless of switch or dimmer position. NOTE: LUT-SHUNT-FM is not for use with 0-10V DIMMER. Use LUT-SHUNT-D-FM.

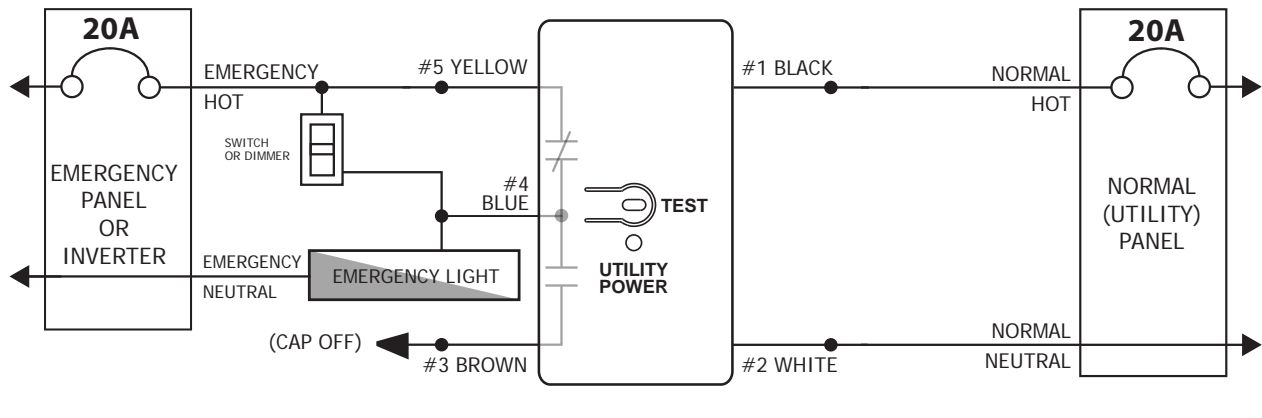

Wiring Diagram #2: For use with Lutron Vive integral fixture controls and DALI drivers with self powered DALI link, such as Philips® SR XI040C110V054VPT1 and XI075C200V054VPT1 and Osram® Dexal (tm) OTi50/120-277/1A4 DX L and OTi30/120-277/1A0 DX L

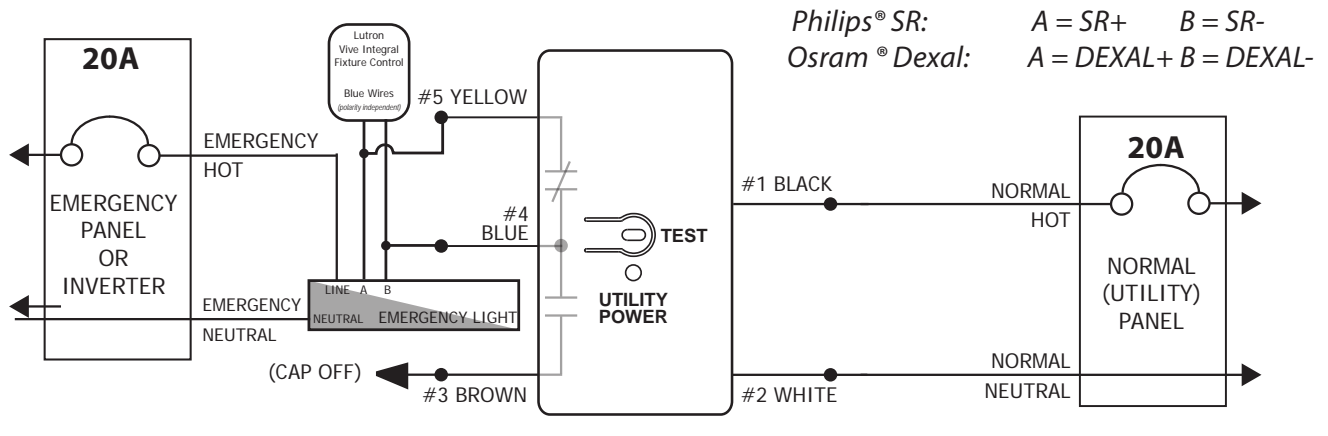

Wiring Diagram #3: For use with Lutron Vive integral fixture controls and EcoSystem drivers without self powered DALI link, such as Lutron LDE1, LDE5, L3D, and L3D0

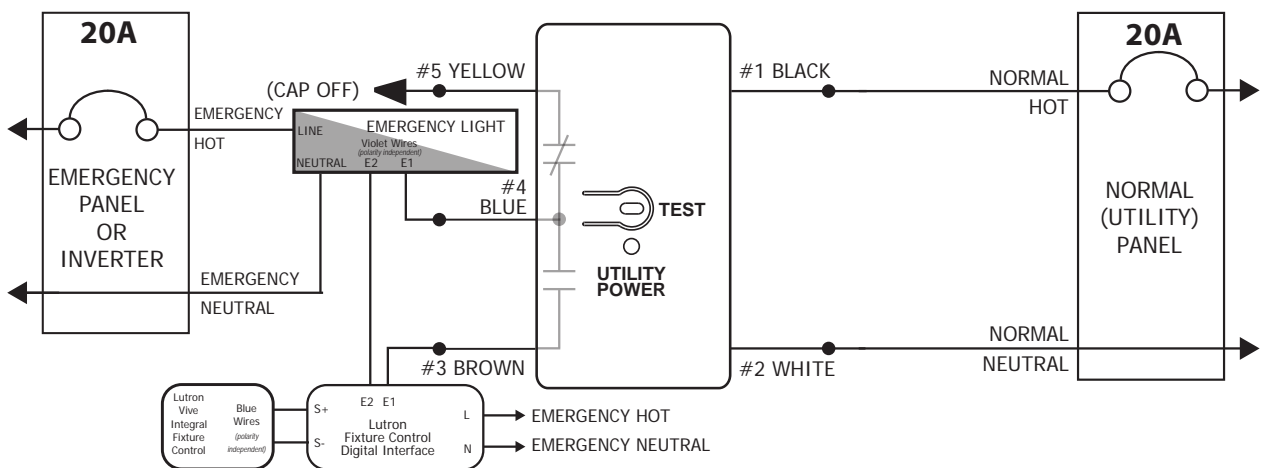

Can I power more than 1 light from the LUT-SHUNT-FM?

It is recommended that the LUT-SHUNT-FM power only one fixture/luminaire.

If you want to control more than one fixture/luminaire, use the higher rated LUT-SHUNT.